



Changzhou **Holry**
Electric Technology Co., Ltd

常州浩瑞电控科技有限公司

Changzhou Holry Electric Technology Co., Ltd

 0086 13646117381

 holry@holrymotor.com

 <http://www.holrymotor.com>

 No. 355, Longjin Road, Lucheng street, Changzhou City, Jiangsu Province, China.

01 Companies resume

Changzhou Holry Electric Technology Co., Ltd. is located in Changzhou, Jiangsu province, which has developed economy and convenient transportation. The company specializes in R&D and production of spindle motors, brushless motors, stepping motors, AC servo motors, reducers and drive systems. The factory was established in 2010 and currently has two brands: Bohong and Holry. Production capacity exceeds more than 1.5 million motors per year. With complete testing equipment, advanced testing methods and strict standards, we devote ourselves to improving the quality and performance of our products and to provide high quality products as per international standards for global engineering-control industry with excellent and quick technical support as well as aftersales service.

Our Products are mainly exported to more than 80 countries including the United States, Italy, Germany, Brazil, Russia, and Pakistan. Our company has successfully passed the quality management system certification for the ISO9001. All products are RoHS compliant and CE certified; some are UL approved.

Holry insists the quality first, innovation and social responsibility as company's concept of development and continues to provide global customers with specialized control motor manufacturing and R&D services.



HYBRID STEPPING MOTOR

BRIEF DESCRIPTION

- Small step angle, high precision;
- The number of pole pairs is equal to the number of rotor teeth, which can be changed in a wide range as required;
- Winding inductance changes little with rotor position, easy to achieve optimal operation control;
- Axial magnetizing magnetic circuit, using a new type of permanent magnet material with high magnetic energy product, which is conducive to the improvement of motor performance;
- The rotor magnet provides excitation; there is no obvious oscillation in the entire operating area.

NAME RULES

42 HB 40 F 105 B-06
 ① ② ③ ④ ⑤ ⑥ ⑦

①: 42: Motor base: 42*42mm

②: HB: Hybrid stepping motor

③: 40: Motor length

④: F: Number of leads: Four-wire, S: Six-wire, E: Eight-wire

⑤: 105: Motor rated current value 1.5A

⑥: B: Motor shaft with flat, CL: gear D: Double Shaft, PJ: key

⑦: 06: Derived number

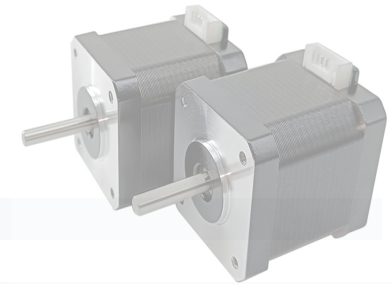

BRIEF INTRODUCTION OF TECHNICAL CHARACTERISTICS

General technical characteristics

- The stepping motor is used in low-speed occasions—the speed does not exceed 1000 revolutions per minute, (6666PPS at 0.9 degrees), preferably between 1000-3000PPS (0.9 degrees), and it can be used here by a deceleration device. At this time The motor has high working efficiency and low noise;
- The stepping motor is best not to use the full-step state, the vibration is large in the full-step state;
- The voltage value in the motor specification is not the driving voltage volt value. The specific driving voltage can be selected according to the stepper driver (recommendations: 42 and below motors use 12-24V, 57 motors use DC 24V-48V, 86 use DC 48-80V, 110 The motor adopts higher than DC 80V)
- When the motor is in a relatively high-speed or large inertia load, it generally does not start at the working speed, but uses a gradual frequency increase to increase the speed. First, the motor does not lose step, and second, it can reduce the noise and improve the positioning accuracy of the stop;
- For high precision, it should be solved by mechanical deceleration, increasing the motor speed, or using a drive with a high subdivision number;
- The motor should not work in the vibration zone. If necessary, it can be solved by changing the voltage, current or adding some damping.;
- The motor works below 600PPS (0.9 degrees) and should be driven by small current, large inductance, and low voltage.

Mechanical technical characteristics

- When installing/removing the shaft end of a stepping motor with a coupling part, do not directly hit the shaft end with a hammer. (The hammer directly hits the shaft end, the encoder on the other end of the stepper motor shaft may be knocked out);
- Try to align the shaft ends to the best condition to ensure good concentricity, otherwise vibration may occur, the bearing may be damaged, and the shaft may even be broken;
- The motor can be used in places that will be attacked by water or oil drops, but it is not completely waterproof or oil-proof. The default protection level is IP54. Therefore, the motor should not be placed or used in an environment that is corroded by water or oil (if special Protection level, please contact us);
- If the motor is connected to a reduction gear, an oil seal should be added when using a stepper motor to prevent the reduction gear from entering the stepper motor;
- Do not immerse the motor cable in oil or water. Make sure that the cable does not receive a moment or vertical load due to external bending force or its own weight, especially at the cable outlet or connection.
- When the motor is moving, the cable (that is, the one configured with the motor) should be firmly fixed to a stationary part (relative to the motor) and an additional cable loaded in the cable support should be used to delay it, so that the bending stress Can be reduced to the minimum. The radius of the cable elbow should be as large as possible.

02 Application Area



03 Company Certificate





HYBRID STEPPING MOTOR—28HB 1.8°

Item	Specifications
Step Angle	1.8°
Step Angle Accuracy	±5% (full Step, no load)
Resistance Accuracy	±10%
Inductance Accuracy	±20%
Temperature Rise	80° C Max.(rated current, 2 phase on)
Ambient Temperature	-20° C~+50° C
Insulation Resistance	100MΩMin. ,500VDC
Dielectric Strength	500VAC for one minute
Shaft Radial Play	0.02Max. (450 g-load)
Shaft Axial Play	0.08Max. (450 g-load)
Insulation Class	B



Technique Specification

Series Model	Motor Length L(mm)	Rated Current (A)	Phase Resistance (Ω)	Phase Inductance (mH)	Holding Torque (Kg.cm)	Lead Wire (NO.)	Rotor Inertia (g.cm ²)	Motor Weight (g)
28HB31F068B	31	0.68	5.6	3.4	0.6	4	9	110
28HB31F095B	31	0.95	2.8	2.3	0.6	4	9	110
28HB44F095B	44	0.95	4.7	3.7	0.9	4	12	140
28HB44F068B	44	0.68	6.8	4.9	0.95	4	12	140
28HB51F095B	51	0.95	5.6	5.0	1.1	4	18	180
28HB51S095B	51	0.95	4.6	1.8	0.9	4	18	180

We also manufacture products according to customer

Dimensions

出轴方式

D型轴

圆轴

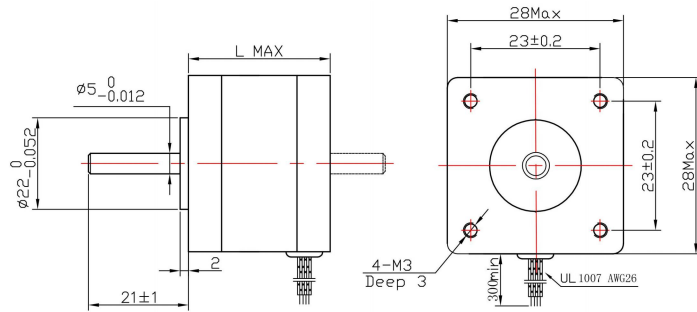

Wiring Diagram

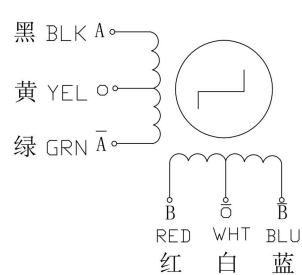
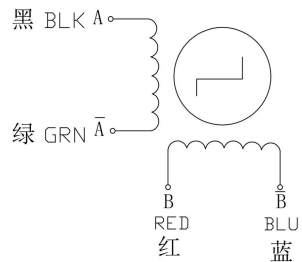

HYBRID STEPPING MOTOR—35HB 1.8°

Item	Specifications
Step Angle	1.8°
Step Angle Accuracy	±5% (full Step, no load)
Resistance Accuracy	±10%
Inductance Accuracy	±20%
Temperature Rise	80° C Max.(rated current, 2 phase on)
Ambient Temperature	-20° C~+50° C
Insulation Resistance	100MΩMin. ,500VDC
Dielectric Strength	500VAC for one minute
Shaft Radial Play	0.02Max. (450 g-load)
Shaft Axial Play	0.08Max. (450 g-load)
Insulation Class	B



Technique Specification

Series Model	Motor Length L(mm)	Rated Current (A)	Phase Resistance (Ω)	Phase Inductance (mH)	Holding Torque (Kg.cm)	Lead Wire (NO.)	Rotor Inertia (g.cm ²)	Motor Weight (g)
35HW27F05AB	27	0.5	20	19	1.0	4	11	110
35HW27F08AB	27	0.8	5.5	5.8	1.0	4	11	110
35HW34S04AB	34	0.4	30	15	1.4	6	13	180
35HW34F06AB	34	0.6	9.0	11	1.3	4	13	180
35HW34F1AB	34	1.0	3.5	5.5	1.3	4	15	180
35HW40F06AB	40	0.6	16.3	18.8	1.8	4	15	200

We also manufacture products according to customer

Dimensions

出轴方式

D型轴

圆轴

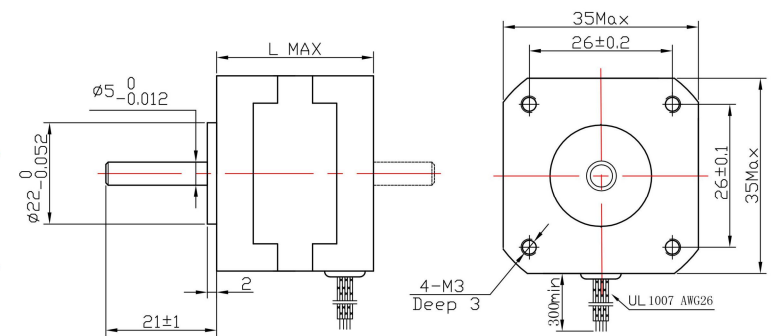

Wiring Diagram

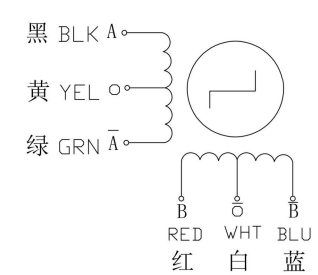
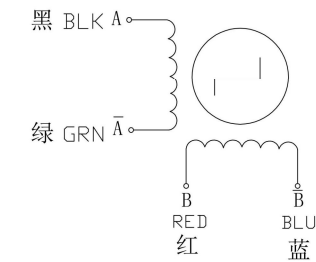



HYBRID STEPPING MOTOR—35HM 0.9°

Item	Specifications
Step Angle	0.9°
Step Angle Accuracy	±5% (full Step, no load)
Resistance Accuracy	±10%
Inductance Accuracy	±20%
Temperature Rise	80° C Max.(rated current, 2 phase on)
Ambient Temperature	-20° C→+50° C
Insulation Resistance	100MΩMin.,500VDC
Dielectric Strength	500VAC for one minute
Shaft Radial Play	0.02Max. (450 g-load)
Shaft Axial Play	0.08Max. (450 g-load)
Insulation Class	B (130°)



Technique Specification

Series Model	Motor Length L(mm)	Rated Current (A)	Phase Resistance (Ω)	Phase Inductance (mH)	Holding Torque (Kg.cm)	Lead Wire (NO.)	Rotor Inertia (g.cm ²)	Motor Weight (g)
35HM27F05AB	27	0.5	20	17	0.9	4	11	110
35HM27F08AB	27	0.8	5.5	5.8	1.0	4	11	110
35HM34S04AB	34	0.4	30	15	1.2	6	11	180
35HM34F05AB	34	0.5	25	25	1.2	4	13	180
35HM34F08AB	34	0.8	6.5	10	1.2	4	13	180

we also manufacture products according to customer

Dimensions

出轴方式

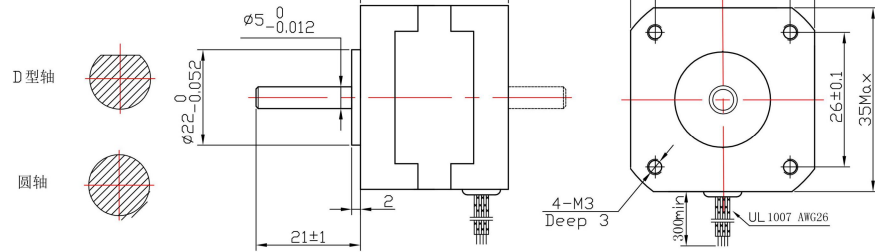

Wiring Diagram

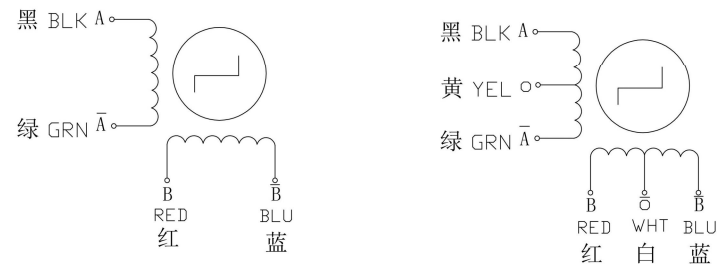

HYBRID STEPPING MOTOR—39HB 1.8°

Item	Specifications
Step Angle	1.8°
Step Angle Accuracy	±5% (full Step, no load)
Resistance Accuracy	±10%
Inductance Accuracy	±20%
Temperature Rise	80° C Max.(rated current, 2 phase on)
Ambient Temperature	-20° C→+50° C
Insulation Resistance	100MΩMin.,500VDC
Dielectric Strength	500VAC for one minute
Shaft Radial Play	0.02Max. (450 g-load)
Shaft Axial Play	0.08Max. (450 g-load)
Insulation Class	B



Technique Specification

Series Model	Motor Length L(mm)	Rated Current (A)	Phase Resistance (Ω)	Phase Inductance (mH)	Holding Torque (Kg.cm)	Lead Wire (NO.)	Rotor Inertia (g.cm ²)	Motor Weight (g)
39HB20F05B	20	0.5	13	6.4	0.7	4	12	100
39HB26F06B	26	0.6	10	10	1.5	4	14	140
39HB34F06B	34	0.6	12	15	2.2	4	19	160
39HB34S03B	34	0.3	40	20	1.3	6	19	160
39HB38F102B	38	1.2	3.8	6.0	2.7	120	24	240
39HB38F04B	38	0.4	30	22	1.8	120	24	240

We also manufacture products according to customer

Dimensions

出轴方式

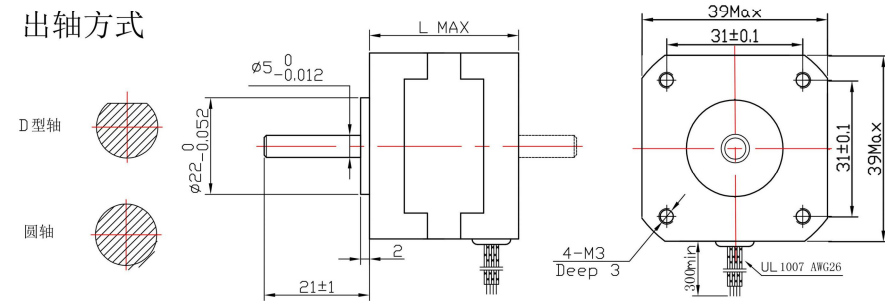

Wiring Diagram

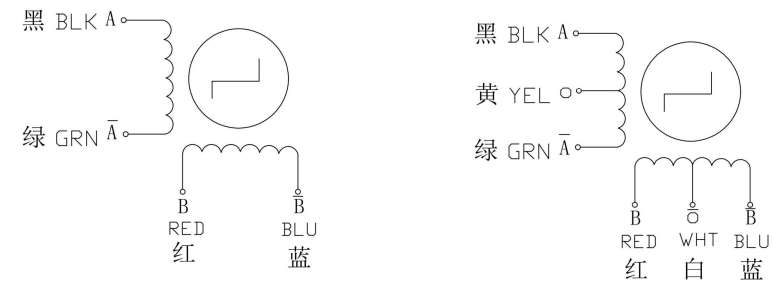



HYBRID STEPPING MOTOR—42HB 1.8°

Item	Specifications
Step Angle	1.8°
Step Angle Accuracy	±5% (full Step, no load)
Resistance Accuracy	±10%
Inductance Accuracy	±20%
Temperature Rise	80° C Max.(rated current, 2 phase on)
Ambient Temperature	-20° C~+50° C
Insulation Resistance	100MΩMin. ,500VDC
Dielectric Strength	500VAC for one minute
Shaft Radial Play	0.02Max. (450 g-load)
Shaft Axial Play	0.08Max. (450 g-load)
Insulation Class	B (130°)



Technique Specification

Series Model	Motor Length L(mm)	Rate Voltage (V)	Rated Current (A)	Phase Resistance (Ω)	Phase Inductance (mH)	Holding Torque (Kg.cm)	Lead Wire (NO.)	Rotor Inertia (g.cm ²)	Motor Weight (g)
42HB34F04AB	34	13.2	0.4	33	45	2.4	4	34	200
42HB34F08AB	34	4.96	0.8	6.2	10	2.4	4	34	200
42HB34F105AB	34	2.7	1.5	1.8	2.4	2.4	4	34	220
42HB40F102AB	40	6.5	1.2	6	13	3.0	4	50	220
42HB40F107AB	40	2.4	1.7	1.5	2.5	3.5	4	50	220
42HB40F05AB	40	4.1	0.5	8	15	2.6	4	50	250
42HB44F05A	44	8.9	0.5	18	23	2.9	4	54	250
42HB44F1AB	44	8	1	8	16	3.5	4	54	250
42HB48F04AB	48	8.0	0.4	20	40	4.0	4	68	280
42HB48F08AB	48	7.2	0.8	9	15	4.5	4	68	280
42HB48F105AB	48	4.2	1.5	2.8	4.8	4.0	4	68	280
42HB62F2AB	62	3.2	2.0	1.6	3.0	8.0	4	75	320

We also manufacture products according to customer

Dimensions

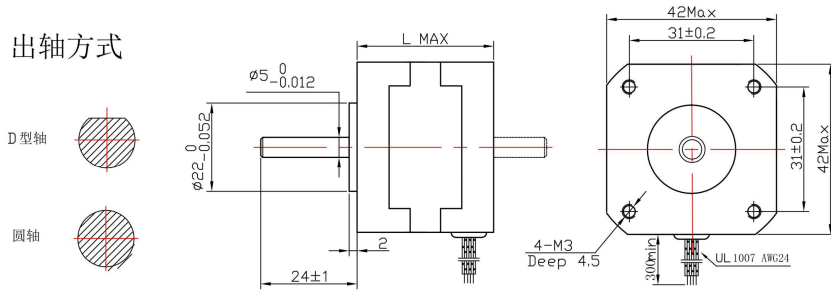

Wiring Diagram

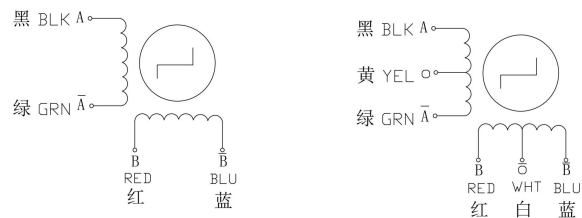

HYBRID STEPPING MOTOR—42HM 0.9°

Item	Specifications
Step Angle	0.9°
Step Angle Accuracy	±5% (full Step, no load)
Resistance Accuracy	±10%
Inductance Accuracy	±20%
Temperature Rise	80° C Max.(rated current, 2 phase on)
Ambient Temperature	-20° C~+50° C
Insulation Resistance	100MΩMin. ,500VDC
Dielectric Strength	500VAC for one minute
Shaft Radial Play	0.02Max. (450 g-load)
Shaft Axial Play	0.08Max. (450 g-load)
Insulation Class	B

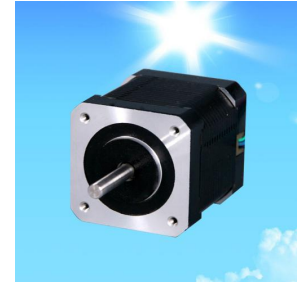

Technique Specification

Series Model	Motor Length L(mm)	Rate Voltage (V)	Rated Current (A)	Phase Resistance (Ω)	Phase Inductance (mH)	Holding Torque (Kg.cm)	Lead Wire (NO.)	Rotor Inertia (g.cm ²)	Motor Weight (g)
42HB34MF06AB	34	4	0.6	4.2	4	1.58	6	34	200
42HB34MF04AB	34	4	0.4	10	9.5	1.58	6	34	200
42HB34MF03A	34	12	0.3	38.5	33	1.58	6	34	200
42HB40MF103B	34	2.8	1.3	2.1	4.2	2.2	4	34	200
42HB40MF102B	40	4	1.2	3.3	4	2.59	6	54	220
42HB40MF08B	40	6	0.8	7.5	7.5	2.59	6	54	220
42HB40M04AB	40	12	0.4	30	30	2.59	6	54	220
42HB40M107AB	40	2.8	1.68	1.65	4	3.3	4	54	220
42HB48MF102AB	48	4	1.2	3.3	4	3.17	4	68	350
42HB48MF04AB	48	12	0.4	30	38	3.17	6	68	350
42HB48MF08AB	48	6	0.8	23	10	3.17	6	68	350
42HB48MF107AB	48	2.8	1.68	1.65	4.1	4.4	4	68	350

we also manufacture products according to customer

Dimensions

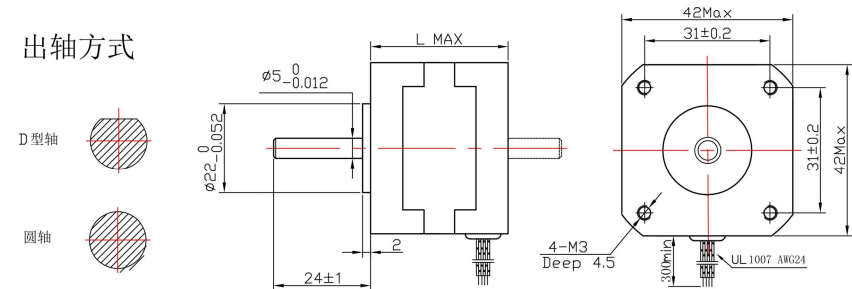

Wiring Diagram

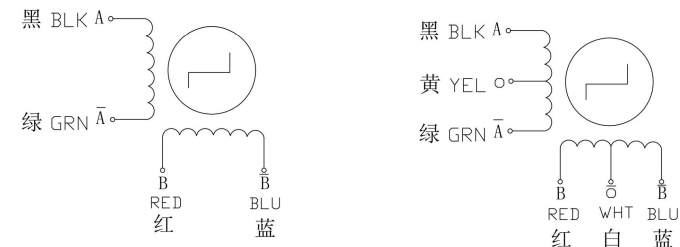



HYBRID STEPPING MOTOR—42HW 3.75°

Item	Specifications
Step Angle	3.75°
Step Angle Accuracy	±5% (full Step, no load)
Resistance Accuracy	±10%
Inductance Accuracy	±20%
Temperature Rise	80° C Max.(rated current, 2 phase on)
Ambient Temperature	-20° C~+50° C
Insulation Resistance	100MΩMin. ,500VDC
Dielectric Strength	500VAC for one minute
Shaft Radial Play	0.02Max.(450 g-load)
Shaft Axial Play	0.08Max.(450 g-load)
Insulation Class	B (130°)



Technique Specification

Series Model	Motor Length L(mm)	Rate Voltage (V)	Rated Current (A)	Phase Resistance (Ω)	Phase Inductance (mH)	Holding Torque (Kg.cm)	Lead Wire (NO.)	Rotor Inertia (g.cm ²)	Motor Weight (g)
42HW25DF08AB	25	9.6	0.8	12	12	0.7	4	24	150
42HW34DS03AB	34	12	0.3	40	18	1.2	6	34	200
42HW34DF06AB	34	12	0.6	20	15	2.0	4	34	200
42HW40DF04AB	40	12	0.4	30	40	3.8	4	54	220
42HW40DF105AB	40	4.5	1.5	3.0	3.5	2.3	4	54	220
42HW48DS04AB	48	12	0.4	30	25	3.2	6	68	280
42HW48DF102AB	48	3.6	1.2	3	5	4.5	4	68	280
42HW48DF205AB	48	3.1	2.5	1.25	1.8	4.8	4	68	280

We also manufacture products according to customer

Dimensions

出轴方式

D型轴



圆轴

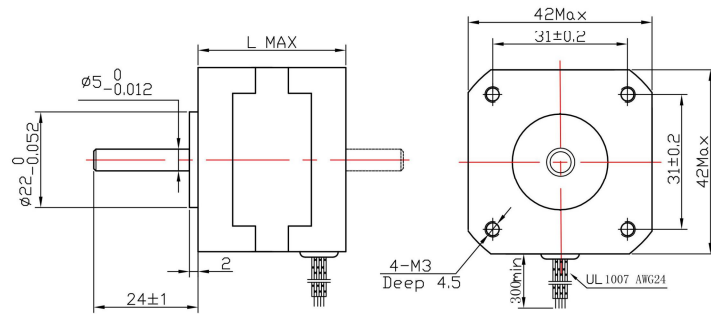

Wiring Diagram

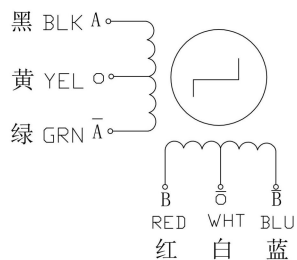
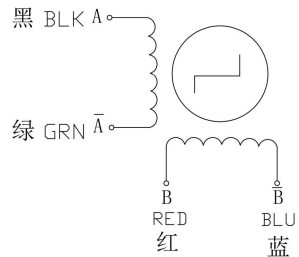

HYBRID STEPPING MOTOR—57HB 1.8°

Item	Specifications
Step Angle	1.8°
Step Angle Accuracy	±5% (full Step, no load)
Resistance Accuracy	±10%
Inductance Accuracy	±20%
Temperature Rise	80° C Max.(rated current, 2 phase on)
Ambient Temperature	-20° C~+50° C
Insulation Resistance	100MΩMin. ,500VDC
Dielectric Strength	500VAC for one minute
Shaft Radial Play	0.02Max.(450 g-load)
Shaft Axial Play	0.08Max.(450 g-load)
Insulation Class	B (130°)



Technique Specification

Series Model	Motor Length L(mm)	Rate Voltage (V)	Rated Current (A)	Phase Resistance (Ω)	Phase Inductance (mH)	Holding Torque (N.M)	Lead Wire (NO.)	Rotor Inertia (g.cm ²)	Motor Weight (Kg)
57HB41F105B	41	2.7	1.5	1.8	4	0.4	4	120	0.45
57HB41F2	41	2	2	1	1.7	0.4	4	120	0.45
57HB41F3	41	3	3	1.0	1.7	0.45	4	120	0.45
57HB51F105B	51	2.6	1.5	5.0	13	0.7	4	275	0.65
57HB51F3	51	3	3	1.1	2.8	0.8	4	275	0.65
57HB56F1B	56	6	1	6.0	16	0.9	4	300	0.7
57HB56F2	56	3.6	2	1.8	2.5	1.0	4	300	0.7
57HB56F3	56	2.5	2.8	0.9	2.5	1.2	4	300	0.7
57HB56S2	56	3.4	2.0	1.7	3.5	0.9	6	300	0.7
57HB64F2	64	7.2	2	3.6	12	1.4	4	360	0.85
57HB64S3	64	7.2	4	0.8	1.2	1.0	6	360	0.85
57HB78F105B	78	6.3	1.5	4.5	15	1.9	4	480	1.1
57HB78F205	78	3.0	2.5	1.2	5.0	1.5	4	480	1.1
57HB78F3	78	3.6	3.0	1.2	5	1.9	4	480	1.1
57HB78S3B	78	3.6	3	1.2	2.5	1.5	6	480	1.1
57HB82F3	82	2.1	3.0	0.7	2.3	2.0	4	530	1.2
57HB78F4BZ	82	2.8	4.0	0.7	2.3	2.1	4	530	1.2

we also manufacture products according to customer

Dimensions

出轴方式

键槽轴

D型轴

五角轴

圆轴

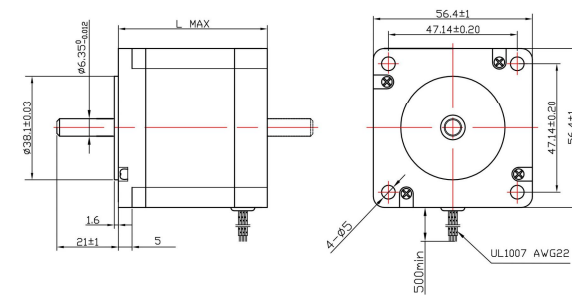

Wiring Diagram

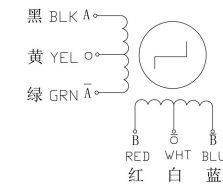
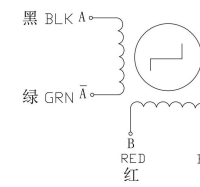



HYBRID STEPPING MOTOR—57HM 0.9°

Item	Specifications
Step Angle	0.9°
Step Angle Accuracy	±5% (full Step, no load)
Resistance Accuracy	±10%
Inductance Accuracy	±20%
Temperature Rise	80° C Max.(rated current, 2 phase on)
Ambient Temperature	-20° C~+50° C
Insulation Resistance	100MΩMin. .500VDC
Dielectric Strength	500VAC for one minute
Shaft Radial Play	0.02Max.(450 g-load)
Shaft Axial Play	0.08Max.(450 g-load)
Insulation Class	B (130°)



Technique Specification

Series Model	Motor Length L(mm)	Rate Voltage (V)	Rated Current (A)	Phase Resistance (Ω)	Phase Inductance (mH)	Holding Torque (N.M)	Lead Wire (NO.)	Rotor Inertia (g.cm ²)	Motor Weight (Kg)
57HB41MSB	41	5.7	1.0	5.7	8	0.4	6	120	0.47
57HB41MS208B	41	2	2.8	1.4	2.2	0.4	6	120	0.47
57HB41MF208B	41	2	2.8	0.7	2.2	0.55	4	120	0.47
57HB56MS1B	56	7.4	1.0	7.4	17.5	0.9	6	300	0.70
57HB56MS208B	56	2.5	2.8	0.9	4.5	0.9	6	300	0.70
57HB56MF208	56	2.5	2.8	0.9	4.5	1.26	4	300	0.70
57HB78MS1B	78	8.6	1.0	8.6	23	1.35	6	480	1.0
57HB78MS2	78	4.5	2.0	2.25	5.6	1.35	6	480	1.0
57HB78MF208B	78	3.2	2.8	1.13	5.6	1.89	4	480	1.0

We also manufacture products according to customer

Dimensions

出轴方式

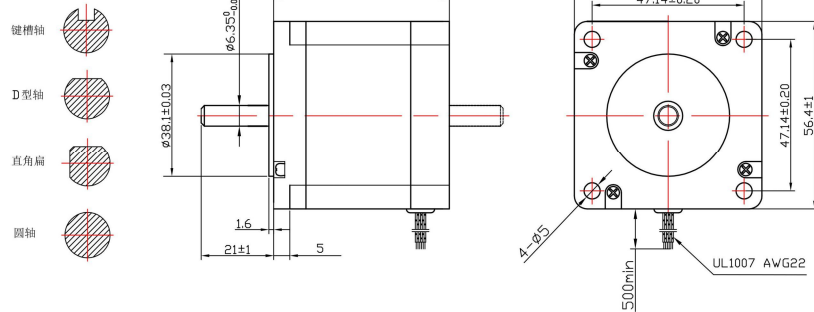

Wiring Diagram

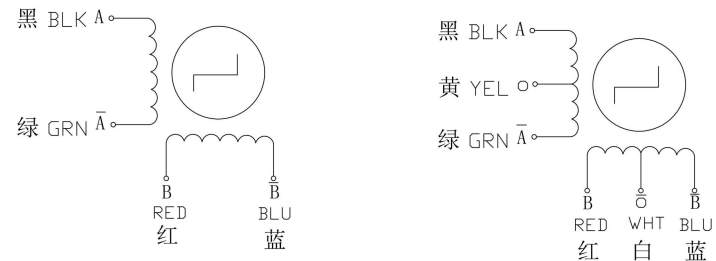

HYBRID STEPPING MOTOR—60HB 1.8°

Item	Specifications
Step Angle	1.8
Step Angle Accuracy	±5% (full Step, no load)
Resistance Accuracy	±10%
Inductance Accuracy	±20%
Temperature Rise	80° C Max.(rated current, 2 phase on)
Ambient Temperature	-20° C~+50° C
Insulation Resistance	100MΩMin. .500VDC
Dielectric Strength	500VAC for one minute
Shaft Radial Play	0.02Max.(450 g-load)
Shaft Axial Play	0.08Max.(450 g-load)
Insulation Class	B (130°)



Technique Specification

Series Model	Motor Length L(mm)	Rate Voltage (V)	Rated Current (A)	Phase Resistance (Ω)	Phase Inductance (mH)	Holding Torque (N.M)	Lead Wire (NO.)	Rotor Inertia (g.cm ²)	Motor Weight (kg)
60HB56F3B	56	3.9	3	1.3	14	1.4	4	300	0.8
60HB56S107B	56	5.8	1.7	3.4	12	1.2	6	300	0.8
60HB56F3PJ	56	2.4	3	0.8	1.6	1.0	4	300	0.8
60HB56F1B	56	12	1	12	15	1.2	4	300	0.8
60HB87F3B	87	4.5	3	1.5	6.8	2.5	4	840	1.4
60HB87F2B	87	6.4	2	3.2	15	2.3	4	840	1.4
60HB87F5B	87	3.25	5	0.65	3.0	2.5	4	840	1.4
60HB87S3PJ	87	4.5	3	1.5	5	2.6	6	840	1.4
60HB87S4B	87	2.6	4	0.65	2.5	3.1	6	840	1.4

We also manufacture products according to customer

Dimensions

出轴方式

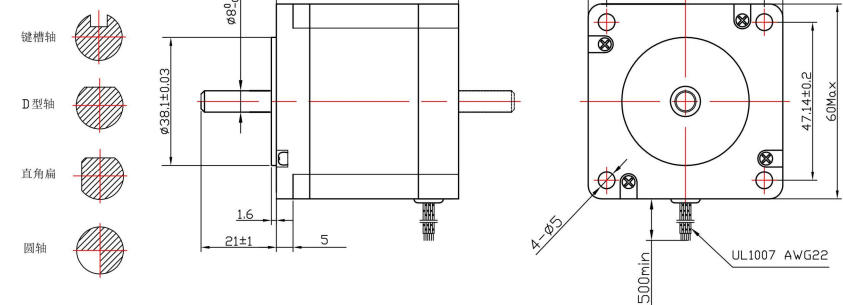

Wiring Diagram

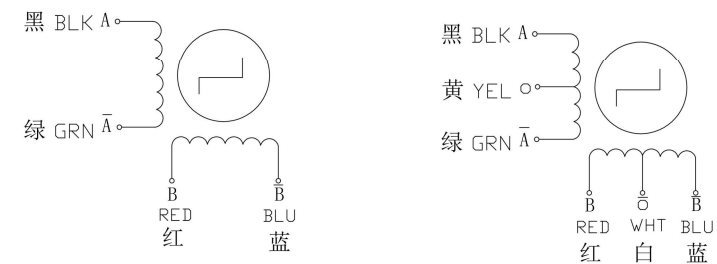



HYBRID STEPPING MOTOR—86HB 1.8°

Item	Specifications
Step Angle	1.8
Step Angle Accuracy	±5% (full Step, no load)
Resistance Accuracy	±10%
Inductance Accuracy	±20%
Temperature Rise	80° C Max.(rated current, 2 phase on)
Ambient Temperature	-20° C~+50° C
Insulation Resistance	100MΩMin.,500VDC
Dielectric Strength	500VAC for one minute
Shaft Radial Play	0.02Max. (450 g-load)
Shaft Axial Play	0.08Max. (450 g-load)
Insulation Class	B (130°)



Technique Specification

Series Model	Motor Length L(mm)	Rate Voltage (V)	Rated Current (A)	Phase Resistance (Ω)	Phase Inductance (mH)	Holding Torque (N.M)	Lead Wire (NO.)	Rotor Inertia (g.cm ²)	Motor Weight (kg)
86HB75F5PJ	75	3.75	5	0.75	7	4.0	4	1400	2.3
86HB75S402B	75	3.36	4.2	0.8	3.5	3.5	6	1400	2.3
86HB80E4PJ	80	3.15	4.0	0.75	3.4	4.5	8	1500	2.5
86HB80F505PJ	80	2.5	5.5	0.45	3	4.5	4	1500	2.5
86HB98F5PJ	98	3	5	0.6	5	6.0	4	1700	3.0
86HB98E2PJ	98	6.4	2	3.2	15	4.4	8	1700	3.0
86HB113F5PJ	113	3	5	0.6	5	7.0	4	2700	3.6
86HB113F305B	113	1.9	3.5	0.53	6.5	5.1	4	2700	3.6
86HB113E6PJ	113	2.6	6	0.43	2.5	4.1	8	2700	3.6
86HB118E402B	118	4.2	4.2	0.9	6	8.5	8	2800	3.8
86HB118F6PJ	118	6.4	6	0.6	6.5	8.5	4	2800	3.8
86HB156E2PJ	156	7.8	2	3.9	20	6.4	8	3600	5.0
86HB156F3PJ	156	5.7	3	1.9	22	10	4	3600	5.0

We also manufacture products according to customer

Dimensions

出轴方式

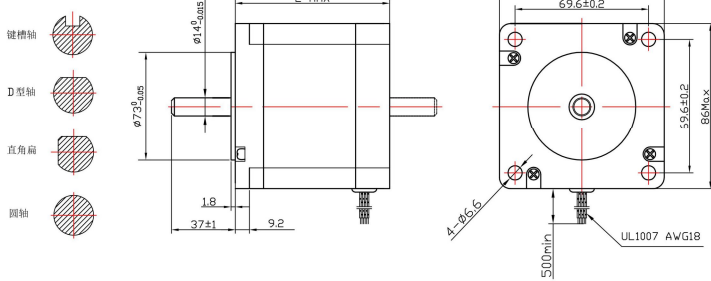

Wiring Diagram

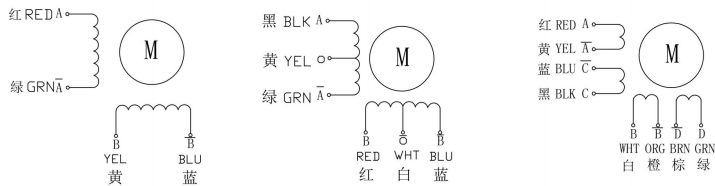

HYBRID STEPPING MOTOR—86HB350 1.2°

Item	Specifications
Step Angle	1.2
Step Angle Accuracy	±5% (full Step, no load)
Resistance Accuracy	±10%
Inductance Accuracy	±20%
Temperature Rise	80° C Max.(rated current, 2 phase on)
Ambient Temperature	-20° C~+50° C
Insulation Resistance	100MΩMin.,500VDC
Dielectric Strength	500VAC for one minute
Shaft Radial Play	0.02Max. (450 g load)
Shaft Axial Play	0.08Max. (450 g load)
Insulation Class	B (130°)



Technique Specification

Series Model	Motor Length L(mm)	Rate Voltage (V)	Rated Current (A)	Phase Resistance (Ω)	Phase Inductance (mH)	Holding Torque (N.M)	Lead Wire (NO.)	Rotor Inertia (g.cm ²)	Motor Weight (kg)
86HB350A-65	65	4	4	1	4	2.3	3	1100	1.65
86HB350A-65	65	7.4	1.75	4.25	12.3	2.5	3	1100	1.65
86HB3558-98	98	4.6	5.8	0.8	3	4.5	3	2320	2.7
86HB3502-98	98	10.8	2	5.4	23	5.0	3	2320	2.7
86HB350-127	127	13	5.2	2.5	13.5	8.0	3	3300	3.5
86HB350C-156	156	4.6	4	3	15	10	3	3600	3.8

We also manufacture products according to customer

Dimensions

出轴方式

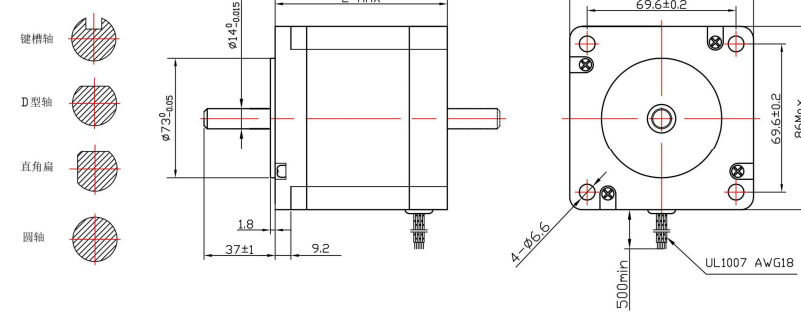

Wiring Diagram

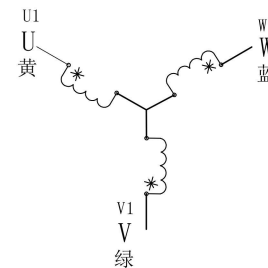



HYBRID STEPPING MOTOR—110HB 1.8°

Item	Specifications
Step Angle	1.8
Step Angle Accuracy	±5% (full Step, no load)
Resistance Accuracy	±10%
Inductance Accuracy	±20%
Temperature Rise	80° C Max.(rated current, 2 phase on)
Ambient Temperature	-20° C~+50° C
Insulation Resistance	100MΩ/Min. ,500VDC
Dielectric Strength	500VAC for one minute
Shaft Radial Play	0.02Max. (450 g load)
Shaft Axial Play	0.08Max. (450 g load)
Insulation Class	B (130°)



Technique Specification

Series Model	Motor Length L(mm)	Rate Voltage (V)	Rated Current (A)	Phase Resistance (Ω)	Phase Inductance (mH)	Holding Torque (N.M)	Lead Wire (NO.)	Rotor Inertia (g.cm ²)	Motor Weight (Kg)
110HB99-001	99	4.95	5.5	0.9	12	8.0	4	5000	5
110HB115-001	115	4.8	6.0	0.8	6	12	4	8000	6.5
110HB150-001	150	5.44	6.8	0.8	15	20	4	10000	8.4
110HB202-001	201	5.36	8	0.67	12	28	4	16200	11.7

We also manufacture products according to customer

Dimensions

出轴方式

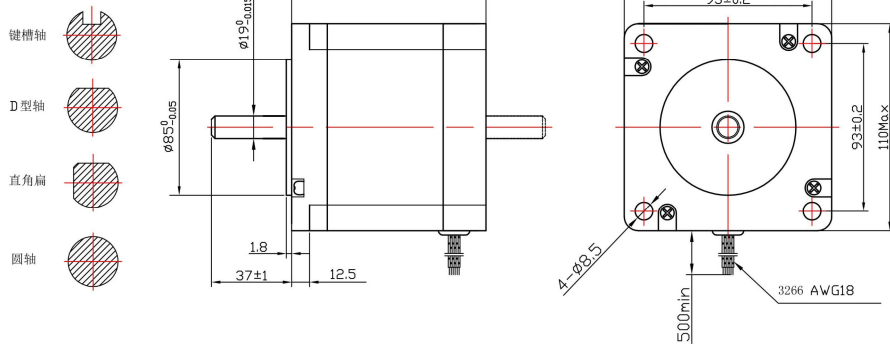

Wiring Diagram

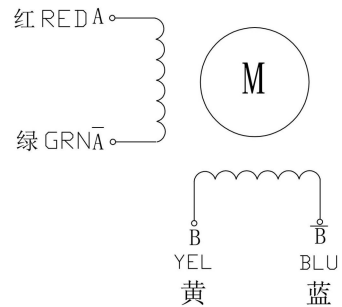

HYBRID STEPPING MOTOR—110HB350 1.2°

Item	Specifications
Step Angle	1.2
Step Angle Accuracy	±5% (full Step, no load)
Resistance Accuracy	±10%
Inductance Accuracy	±20%
Temperature Rise	80° C Max.(rated current, 2 phase on)
Ambient Temperature	-20° C~+50° C
Insulation Resistance	100MΩ/Min. ,500VDC
Dielectric Strength	500VAC for one minute
Shaft Radial Play	0.02Max. (450 g load)
Shaft Axial Play	0.08Max. (450 g load)
Insulation Class	B (130°)



Technique Specification

Series Model	Motor Length L(mm)	Rate Voltage (V)	Rated Current (A)	Phase Resistance (Ω)	Phase Inductance (mH)	Holding Torque (N.M)	Lead Wire (NO.)	Rotor Inertia (g.cm ²)	Motor Weight (Kg)
110HB350-12	129	80-325	6.0	1.0	15	12	3	5000	5
110HB350-16	168	80-325	6.8	0.8	15	16	3	10000	8.4
110HB350-21	201	80-325	8	0.67	12	21	3	16200	11.7

We also manufacture products according to customer

Dimensions

出轴方式

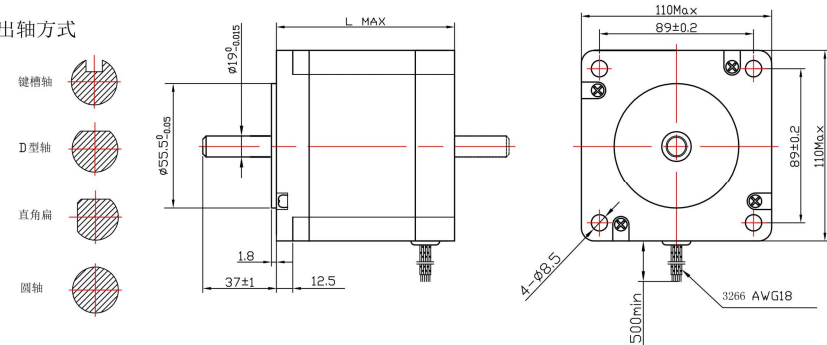

Wiring Diagram

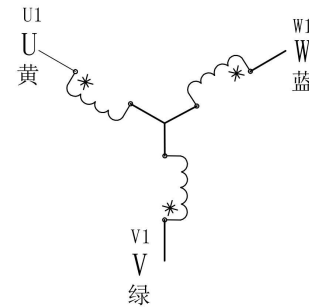



HYBRID LINEAR STEPPING MOTOR—28HBSG

Optional screw parameters

Diameter(mm)	Screw Pitch(mm)	Lead (mm)	Starts(mm)	Step Size(mm)
3.5	1.216	1.216	1	0.006
5.56	1.22	2.44	2	0.0122
5.56	1.22	9.76	8	0.006
6	1.5	1.5	1	0.0075
6.35	1.22	4.88	4	0.0244
6.35	1.5875	3.175	2	0.008
6.35	0.794	0.794	1	0.004
6.5	1.5	3	2	0.015
8	1	1	1	0.005
8	2	2/4/8	1/2/4	0.01/0.02/0.04



Technique Specification

Series Model	Step Angle (°)	Motor Length L2(mm)	Rated Current (A)	Phase Resistance (Ω)	Phase Inductance (mH)	Holding Torque (Kg.cm)	Detent Torque (g.cm)	Rotor Inertia (g.cm ²)	Lead Wire (NO.)	Motor Weight (g)
28HB31F09SG	1.8	31	0.95	2.8	0.8	0.8	15	9	4	110
28HB31F06SG	1.8	31	0.68	5.6	3.4	0.6	15	9	4	110
28HB44F09SG	1.8	44	0.95	3.4	1.2	1.2	35	12	4	140
28HB44F06SG	1.8	44	0.68	6.8	4.9	0.95	35	11	4	140
28HB51F09SG	1.8	51	0.95	4.6	1.8	1.5	50	18	4	200
28HB51F06SG	1.8	51	0.68	9.2	7.2	1.2	50	18	4	200

We also manufacture products according to customer

Dimensions

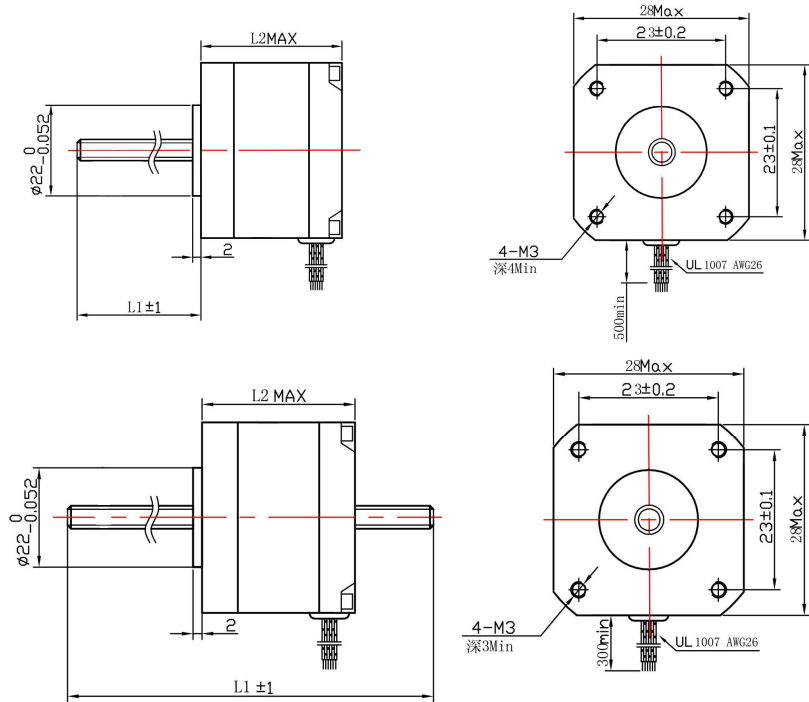

HYBRID LINEAR STEPPING MOTOR—35HBSG

Optional screw parameters

Diameter(mm)	Screw Pitch(mm)	Lead (mm)	Starts(mm)	Step Size(mm)
5.56	1.22	2.44	2	0.0122
5.56	1.22	9.76	8	0.006
6	1.5	1.5	1	0.0075
6.35	1.22	4.88	4	0.0244
6.35	1.5875	3.175	2	0.008
6.35	0.794	0.794	1	0.004
6.5	1.5	3	2	0.015
8	1	1	1	0.005
8	2	2/4/8	1/2/4	0.01/0.02/0.04



Technique Specification

Series Model	Step Angle (°)	Motor Length L2(mm)	Rated Current (A)	Phase Resistance (Ω)	Phase Inductance (mH)	Holding Torque (Kg.cm)	Detent Torque (g.cm)	Rotor Inertia (g.cm ²)	Lead Wire (NO.)	Motor Weight (g)
35HB27F05SG	1.8	27	0.5	20	17	1.3	50	11	4	110
35HB27F08SG	1.8	27	0.8	5.5	5.8	1.3	50	11	4	110
35HB27S04SG	1.8	27	0.4	30	10	1.0	50	11	6	110
35HB34F05SG	1.8	34	0.5	25	25	1.8	80	13	4	180
35HB34F08SG	1.8	34	0.8	6.5	10	1.8	80	13	4	180
35HB34S04SG	1.8	34	0.4	30	15	1.4	80	13	6	180

We also manufacture products according to customer

Dimensions

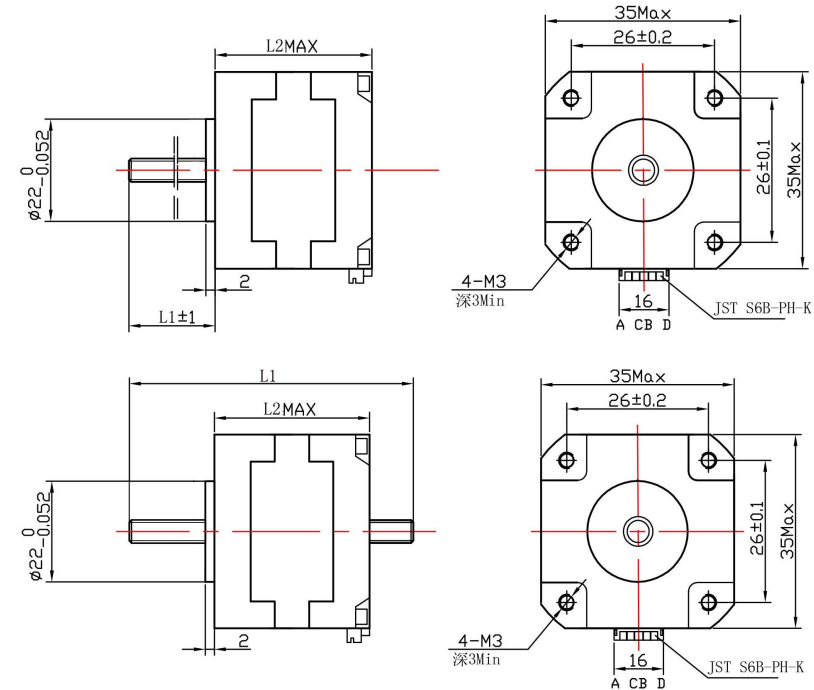



HYBRID LINEAR STEPPING MOTOR—42HBSG

Optional screw parameters

Diameter(mm)	Screw Pitch(mm)	Lead (mm)	Starts(mm)	Step Size(mm)
6	1.5	1.5	1	0.0075
6.35	1.22	4.88	4	0.0244
6.35	1.5875	3.175	2	0.008
6.35	0.794	0.794	1	0.004
6.5	1.5	3	2	0.015
8	1	1	1	0.005
8	2	2/4/8	1/2/4	0.01/0.02/0.04



Technique Specification

Model	Step angle (°)	Motor Length L2(mm)	Rate Voltage (V)	Rate Current (A)	Phase Resistance (Ω)	Phase Inductance (mH)	Holding Torque (g.cm)	Lead Wire (No.)	Liang Rotor Inertia (g.C m ²)	Detent Torque (g.cm)	Motor Weight (kg)
42HB34F04SG	1.8	34	13.2	0.4	33	45	2.4	4	34	120	0.2
42HB34F08SG	1.8	34	4.96	0.8	6.2	10	2.4	4	34	120	0.2
42HB34F10SSG	1.8	34	2.7	1.5	1.8	2.4	2.4	4	34	120	0.26
42HB40F04SG	1.8	40	12	0.4	30	45	3.8	4	54	150	0.26
42HB40F08SG	1.8	40	8.8	0.8	11	26	4.0	4	54	150	0.26
42HB40F10SSG	1.8	40	3.15	1.5	2.1	4.0	3.5	4	54	150	0.36
42HB48F08SG	1.8	48	7.2	0.8	9	15	4.5	4	68	200	0.36
42HB48F107SG	1.8	48	3.4	1.7	2.0	3.0	4.5	4	68	200	0.36
42HB62F105SG	1.8	62	4	1.5	2.7	6.0	6.5	4	102	280	0.5
42HB62F2SG	1.8	62	3.2	2.0	1.6	3.0	8	4	102	280	0.5

We also manufacture products according to customer

Dimensions

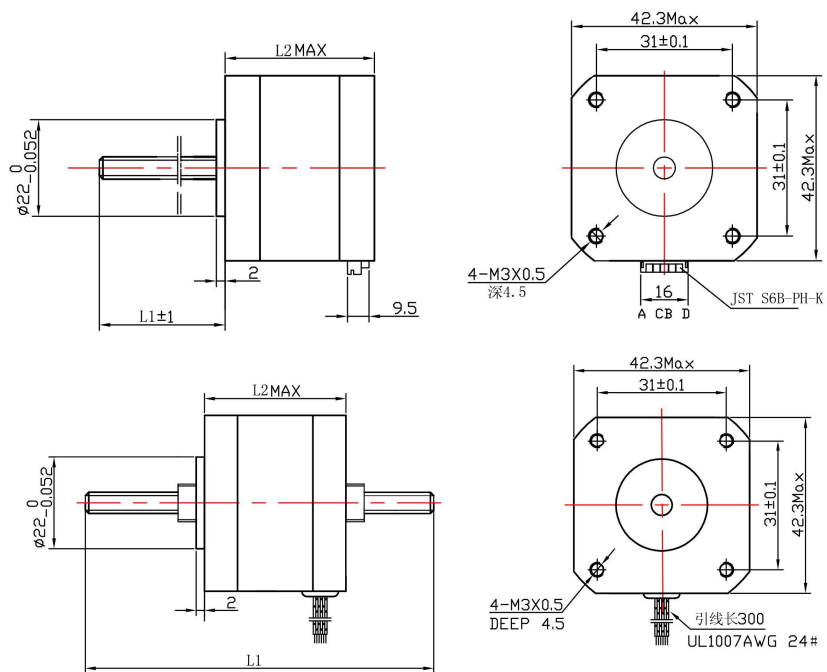

HYBRID LINEAR STEPPING MOTOR—57HBSG

Optional screw and step

Diameter(mm)	Screw Pitch(mm)	Lead (mm)	Starts(mm)	Step Size(mm)
8	1	1	1	0.005
8	2	2/4/8	1/2/4	0.01/0.02/0.04
9.525	1.5875	1.5875	1	0.008
9.525	2.54	5.08/10.16	2/4	0.0254/0.0508
10	2	4	2	0.02
10	4	20	5	0.1
12	2	4	2	0.02
12	2.5	5	2	0.025
12	3	15	5	0.075



Technique Specification

Model	Step angle (°)	Motor Length L2(mm)	Rate Voltage (V)	Rate Current (A)	Phase Resistance (Ω)	Phase Inductance (mH)	Holding Torque (kg.cm)	Lead Wire (NO.)	Rotor Inertia (g.c m ²)	Detent Torque (g.cm)	Motor Weight (kg)
57HB41F102SG	1.8	41	6.6	1.2	5.5	10	5	4	120	210	0.45
57HB41F2SG	1.8	41	2.0	2.0	1.0	1.7	5	4	120	210	0.45
57HB56F1SG	1.8	56	5.92	1.6	3.7	12.5	9	4	135	400	0.7
57HB56F3SG	1.8	56	3.0	3.0	1.0	3.0	9	4	135	400	0.7
57HB64F2SG	1.8	64	7.0	2.0	3.6	12	12.6	4	145	420	0.72
57HB78F105SG	1.8	78	6.8	1.5	4.5	15	13	4	200	720	0.95
57HB78F3SG	1.8	78	2.7	3	0.9	3	15	4	200	720	0.95

We also manufacture products according to customer

Dimensions

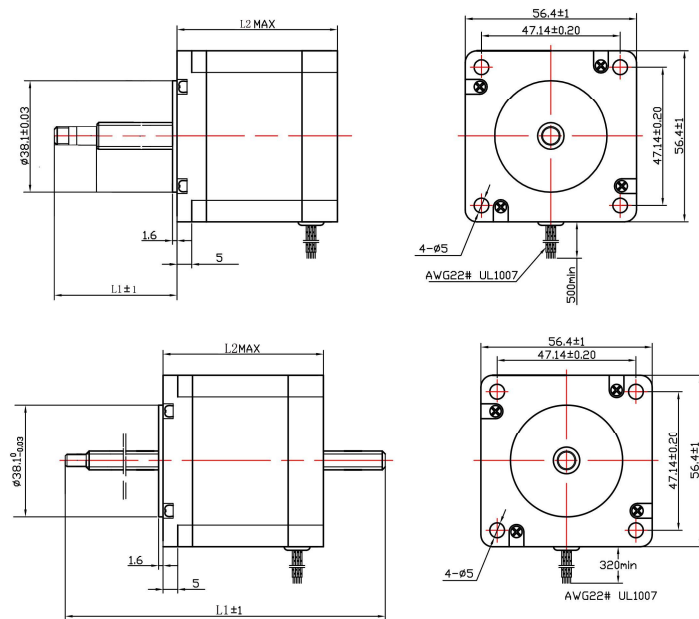



HYBRID LINEAR STEPPING MOTOR—86HBSG

Optional screw and step

Diameter(mm)	Screw Pitch(mm)	Lead (mm)	Starts(mm)	Step Size(mm)
12	2	4	2	0.02
12	2.5	5	2	0.025
12	3	15	5	0.075



Technique Specification

Model	Step angle (°)	Motor Length L2(mm)	Rate Voltage (V)	Rate Current (A)	Phase Resistance (Ω)	Phase Inductance (mH)	Holding Torque (N.m)	Lead Wire (NO.)	Rotor Inertia (kg.cm ²)	Motor Weight (kg)
86HB80S4SG	1.8	80	6.4	4.0	1.6	6.0	3.8	6	1.5	2.3
86HB80F205SG	1.8	80	2.5	5.5	0.45	3	4.5	4	1.5	2.3
86HB98E4SG	1.8	98	3.2	4	0.8	3.5	4.3	8	1.7	3
86HB98F5G	1.8	98	2.5	5	0.5	3.5	6.5	4	1.7	3
86HB113F305SG	1.8	113	1.9	3.5	0.53	6.5	7.0	4	2.7	3.6
86HB113E6SG	1.8	113	2.6	6	0.43	2.5	4.1	8	2.7	3.6
86HB156F505SG	1.8	156	4.4	5.5	0.8	7.5	10	4	4	5

We also manufacture products according to customer

Dimensions

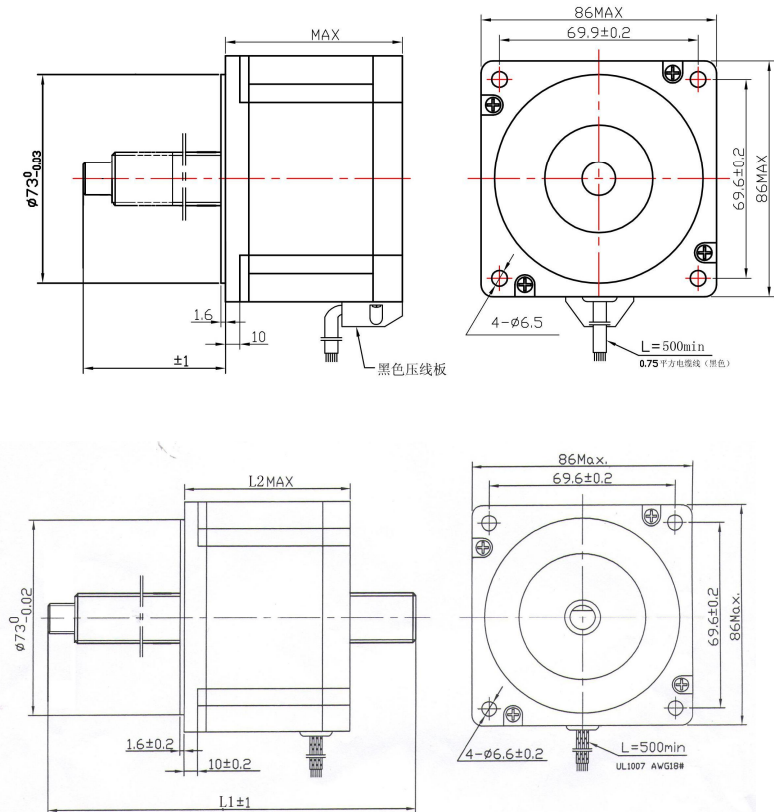

HYBRID LINEAR STEPPING MOTOR

Ball screw series

Mounting dimensions for ball screws and nuts								
d	I	D	A	B	L	W	H	X
4	1	10	20	3	12	15	14	2.9
6	1	12	24	3.5	15	18	16	3.4
8	1	14	27	4	16	21	18	3.4
	2	14	27	4	16	21	18	3.4
	2.5	16	29	4	26	23	20	3.4
12	4	24	40	10	40	32	30	4.5
	5	28	48	10	50	38	40	5.5
16	10	28	48	10	57	38	40	5.5
	4	36	58	10	42	47	44	6.6
20	5	36	58	10	51	47	44	6.6

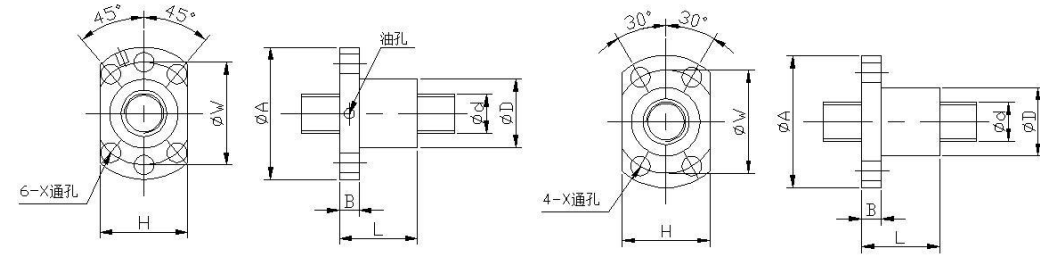

Technique Specification

Frame Size mm	Model number	Motor Length L2(mm)	Rated Voltage V	Rated Voltage V	Rate Current A	Phase Resistance Ω	Phase Inductance mH	Holding Torque Kg-cm	Lead Wire NO.	Rotor Inertia g-cm ²	detent torque g-cm
42	42HB34S04GSG	34	9.6	9.6	0.4	24	15	1.6	6	35	120
	42HB34F103GSG	34	2.8	2.8	1.33	2.1	2.5	2.2	4	35	120
	42HB40S08GSG	40	6	6	0.8	7.5	6.7	2.6	6	54	150
	42HB40F107GSG	40	2.8	2.8	1.68	1.65	3.2	3.6	4	54	150
	42HB48S102GSG	48	4	4	1.2	3.3	2.8	3.17	6	68	200
	42HB48F107GSG	48	2.8	2.8	1.68	1.65	2.8	4.4	4	68	200
57	42HB62F102GSG	62	7.2	7.2	1.2	6	7	6.5	6	102	280
	57HB41S1GSG	41	5.7	5.7	1	5.7	5.4	3.9	6	120	210
	57HB41F208GSG	41	2	2	2.8	0.7	1.4	5.5	4	120	210
	57HB56S1GSG	56	7.4	7.4	1	7.4	10	9.0	6	300	410
	57HB56F205GSG	56	2.5	2.5	2.8	0.9	2.5	12.6	4	300	410
	57HB78S2GSG	78	4.5	4.5	2	2.25	3.6	13.5	6	480	680
86	57HB78F208GSG	78	3.2	3.2	2.8	1.13	3.6	18.9	4	480	680
	86HB65F4GSG	65	2.0	2.0	4.0	0.7	3.0	35	4	1000	800
	86HB80F5GSG	80	3.75	3.75	5.0	0.75	5.5	40	4	1400	2700
	86HB80E4GSG	80	6.7	6.7	4.2	1.6	6	42	8	1400	2700
	86HB113F5GSG	113	3	3	5	0.6	5	80	4	2700	2700
	86HB113S4GSG	113	4.8	4.8	4	1.2	5	65	8	2700	2700
	86HB156F505GS G	156	4.4	4.4	5.5	0.8	7.5	100	4	4000	3600

We also manufacture products according to customer



GEARBOX STEPPING MOTOR

28 series

Technique Specification

Model	Step angle (°)	Motor Length L2(mm)	Rate Voltage (V)	Rate Current (A)	Phase Resistance (Ω)	Phase Inductance (mH)	Holding Torque (kg.cm)	Lead Wire (No.)	Motor Weight (kg)
28HB31F095AJ	1.8	31	0.95	2.8	2.3	0.6	0.6	9	110
28HB44F095AJ	1.8	44	0.95	4.7	3.7	0.9	0.9	12	140
28HB51F095AJ	1.8	51	0.95	5.6	5.0	1.1	1.2	18	180

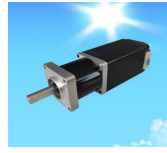

We also manufacture products according to customer

Available reducer data

Reduction ratio	3,71,5,18	13,7,19,2,27	51,71,99,139
Length L1	mm 31	41	51
Rated torque	Nm 0.4	0.4	0.4
Maximum load	Nm 0.6	0.6	0.6
Efficiency	% 90	81	73
Backlash	arcmin ≤60	≤75	≤90

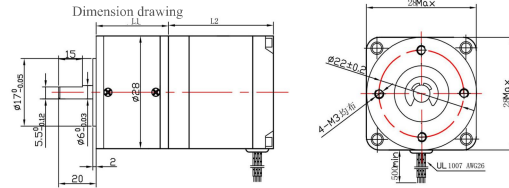

42 series

Technique Specification

Model	Step angle (°)	Motor Length L2(mm)	Rate Voltage (V)	Rate Current (A)	Phase Resistance (Ω)	Phase Inductance (mH)	Holding Torque (kg.cm)	Lead Wire (No.)	Motor Weight (kg)
42HB34F08AJ	1.8	34	4.96	0.8	6.2	10	2.4	4	0.7
42HB34F105AJ	1.8	34	2.7	1.5	1.8	2.4	2.4	4	0.7
42HB40F107AJ	1.8	40	3.15	1.5	2.1	4.0	3.5	4	0.9
42HB48F107AJ	1.8	48	3.4	1.7	2.0	3.0	4.5	4	1.0



We also manufacture products according to customer

Available reducer data

Reduction ratio	3,71,5,18	13,7,19,2,27	51,71,99,139
Length L1	mm 31	41	51
Rated torque	Nm 0.4	0.4	0.4
Maximum load	Nm 0.6	0.6	0.6
Efficiency	% 90	81	73
Backlash	arcmin ≤60	≤75	≤90

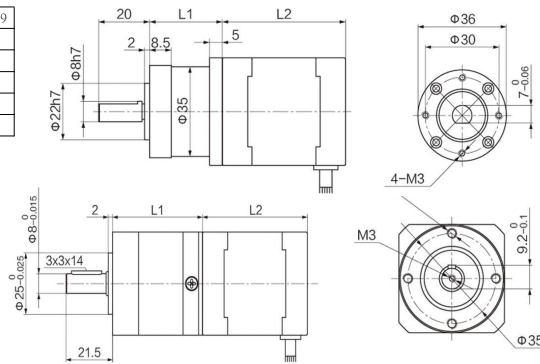

Precision type

Reduction ratio	4,5, 10	16, 20, 25, 40, 45, 50, 100
Length L1	mm 42	52
Rated torque	Nm 3.5	15
Maximum load	Nm 6	25
Efficiency	% 95	90
Backlash	arcmin ≤15	≤25



57 series

Technique Specification

Model	Step angle (°)	Motor Length L2(mm)	Rate Voltage (V)	Rate Current (A)	Phase Resistance (Ω)	Phase Inductance (mH)	Holding Torque (kg.cm)	Lead Wire (NO.)	Motor Weight (kg)
57HB41F2AJ	1.8	41	2.0	2.0	1.0	1.7	5	4	1.4
57HB56F3AJ	1.8	56	3.0	3.0	1.0	3.0	9	4	1.7
57HB64F2SG	1.8	64	7.0	2.0	3.6	12	12.6	4	1.8
57HB78F105AJ	1.8	78	6.8	1.5	4.5	15	13	4	1.9
57HB78F3SAJ	1.8	78	2.7	3	0.9	3	15	4	1.9



We also manufacture products according to customer

Available reducer data

Common type

Reduction ratio	3,6,4,25	13,15,18	47,55,65,77
Length L1	mm 31	41	63.1
Rated torque	Nm 9	15	24
Maximum load	Nm 26	44	71
Efficiency	% 90	81	73
Backlash	arcmin ≤60	≤75	≤90

Precision type

Reduction ratio	4,5, 10	16, 20, 25, 40, 45, 50, 100
Length L1	mm 53	70
Rated torque	Nm 6	25
Maximum load	Nm 12	40
Efficiency	% 95	90
Backlash	arcmin ≤15	≤25

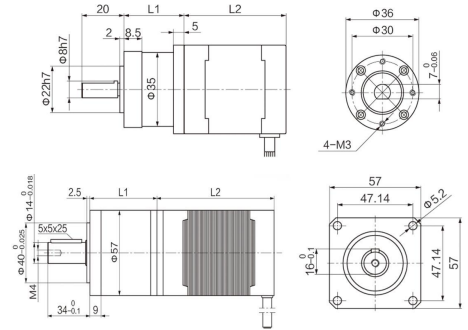

86 series

Technique Specification

Model	Step angle (°)	Motor Length L2(mm)	Rate Voltage (V)	Rate Current (A)	Phase Resistance (Ω)	Phase Inductance (mH)	Holding Torque (N.M)	Lead Wire (NO.)	Motor Weight (kg)
86HB80F205AJ	1.8	80	2.5	5.5	0.45	3	4.5	4	5
86HB98F5AJ	1.8	98	2.5	5	0.5	3.5	5.0	4	5.5
86HB113F4AJ	1.8	113	3.0	4.0	0.6	5.0	6.5	4	6.2
86HB156F5AJ	1.8	156	4.4	5.5	0.8	7.5	10	4	7.5



We also manufacture products according to customer

Available reducer data

Reduction ratio	4,5, 10	16, 20, 25, 40, 45, 50, 100
Length L1	mm 73	87
Rated torque	Nm 50	80
Maximum load	Nm 100	160
Efficiency	% 96	94
Backlash	arcmin ≤15	≤25

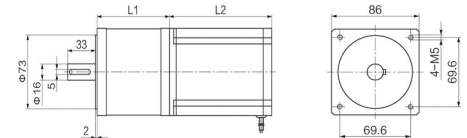

The deceleration stepper motor is generally used when a higher torque is required in a limited space, that is, a small volume and a large torque. The reliability and life of planetary reduction stepper motors are better than gear reducers. The gear reducer is light in weight, small in size and low in cost.

◆ The above optional stepper motors are only representative products, and can also be made according to user requirements, such as current resistance size, dual output shafts, and deceleration stepper motor shaft output methods.

◆ Calculation formula for output speed of decelerating stepper motor: Motor output speed = Stepper motor speed ÷ Reduction ratio

◆ Calculation formula for output torque of decelerating stepper motor: Motor output torque = Stepper motor torque × Reduction ratio × Effective value

◆ For example, reduction ratio: 5. The torque of the selected stepping motor at a speed of 300 revolutions/min is 0.2N.m. Then the corresponding output of the decelerating stepper motor is that the output torque is 0.92N.m at 60 rpm.



DRIVERS---BHD2506

The BHD2506 is a new type of stepper driver successfully researched and developed according to the market demand and development trend. It adopts a new 32-bit motor control special DSP chip, which makes the motor run more smoothly and is not easy to lose steps. The BHD2806 receives input signal pulse, direction and enable input. When using the internal position, the pulse and direction interfaces can be used for sensor signal input and accept 485 control operation. The motor's heat generation and vibration amplitude are reduced to a minimum, thus better improving machining speed and accuracy of machine operation. Operating voltage is DC24-50V, and is compatible with various types of two-phase stepper motors with currents up to 4.0A and outer diameters from 42 to 57mm.

Technical characteristics

- Brand new 32-bit DSP chip for motor control;
- Can drive stepper motors in the 60 series and below;
- Pulse response frequencies up to 200 Kpps;
- Opto-isolated signal input;
- High speed, high torque, high energy efficiency;
- With overcurrent, over-voltage protection.

Electrical Specifications

Specifications	Minimum value	Typical value	Peak value	Unit
Continuous output current	0	4	6	A
Input power voltage	+24v	--	50v	Vdc
Pulse frequency	0	--	200	KHz
Input signal current	7	10	20	MA
insulation resistance	500	--	-	MΩ

Operating environment and parameters

Cooling method		Natural wind cooling or forced cooling
Ambient environment	Environment	No corrosive gas or dust, etc. Cannot be used in special environments such as radioactive materials, magnetic fields, and vacuum.
	Temperature	0---+50°C
	Humidity	Under 85%(no dew)
Storage temperature		-20°C--80°C
Weight		Around 480 grams
Dimensions		118*75.5*33 mm3

External terminal descriptio

Dimensions

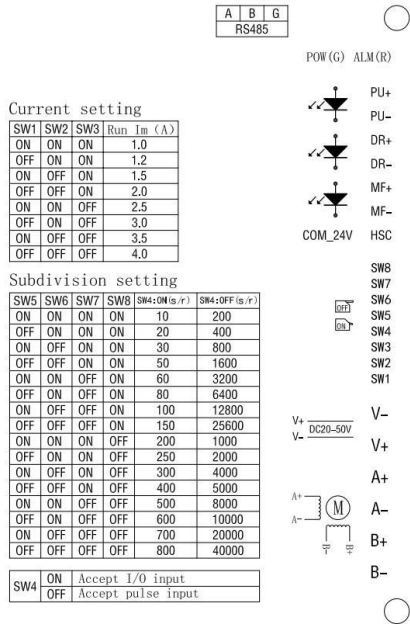

Current setting

SW1	SW2	SW3	Run	I _m (A)
ON	ON	ON	1.0	
OFF	ON	ON	1.2	
ON	OFF	ON	1.5	
OFF	OFF	ON	2.0	
ON	ON	OFF	2.5	
OFF	ON	OFF	3.0	
ON	OFF	OFF	3.5	
OFF	OFF	OFF	4.0	

Subdivision setting

SW5	SW6	SW7	SW8	SW4=ON (s/r)	SW4=OFF (s/r)
ON	ON	ON	ON	10	200
OFF	ON	ON	ON	20	400
ON	OFF	ON	ON	30	800
OFF	OFF	ON	ON	50	1600
ON	ON	OFF	ON	60	3200
OFF	ON	OFF	ON	80	6400
ON	OFF	OFF	ON	100	12800
OFF	OFF	OFF	ON	150	25600
ON	ON	ON	OFF	200	1000
OFF	ON	ON	OFF	250	2000
ON	OFF	ON	OFF	300	4000
OFF	OFF	ON	OFF	400	8000
ON	ON	OFF	OFF	500	10000
OFF	ON	OFF	OFF	600	20000
ON	OFF	OFF	OFF	700	40000
OFF	OFF	OFF	OFF	800	40000

SW4	ON	Accept I/O input
	OFF	Accept pulse input

Subdivision settings / I / O mode settings

The subdivision (micro step) setting and the I/O mode setting are controlled by the dip switch SW4. When SW4=OFF, it is subdivision setting mode; when SW4=ON, it is I/O mode. The subdivision and speed are set by the DIP switch SW5~SW8, total 16 steps.

subdivision number (puls/r)	200	400	800	1600	3200	6400	12800	25600
Speed (rpm)	10	20	30	50	60	80	100	150
SW5	ON	OFF	ON	OFF	ON	OFF	ON	OFF
SW6	ON	ON	OFF	OFF	ON	ON	OFF	OFF
SW7	ON	ON	ON	ON	OFF	OFF	OFF	OFF
SW8	ON	ON	ON	ON	ON	ON	ON	ON
subdivision number (puls/r)	1000	2000	4000	5000	8000	10000	20000	40000
Speed (rpm)	200	250	300	400	500	600	700	800
SW5	ON	OFF	ON	OFF	ON	OFF	ON	OFF
SW6	ON	ON	OFF	OFF	ON	ON	OFF	OFF
SW7	ON	ON	ON	ON	OFF	OFF	OFF	OFF
SW8	ON	OFF	OFF	OFF	OFF	OFF	OFF	OFF

1. The input voltage should not exceed DC50V
2. In position mode, the falling edge of the input pulse signal is valid;
3. When the temperature of the drive exceeds 80 °C, the driver stops working, and the fault indicator lamp ALM lights up. Until the temperature of the drive drops to 50 °C, the driver needs to be powered on again to resume working. In case of overheating protection, please install radiator;
4. Over current (load short circuit) fault indicator lamp ALM is on. Please check the motor wiring and
5. other short circuit faults, and power on again after troubleshooting;
6. No motor fault indicator lamp ALM on, please check the motor wiring, after which the motor needs to be restarted.

Pin function description

Symbol	Function	Note
PU-	Pulse signal	The falling edge is valid, the motor takes one step when the pulse changes from high to low, the input resistance is 220 Ω, the requirements are: low level 0-0.5V, high level more than 4V, pulse width >2.5μs.
DR+	Input opto-isolated signal +	Connect the 5V positive terminal of the signal power supply, and switch to the COM24V interface when it is higher than +5V.
DR-	Direction control signal	Used to change the direction of the motor. Input resistance 220 Ω, requirements: low level 0-0.5V, high level greater than 4V, pulse width > 2.5 μ s.
MF+	Input opto-isolated signal +	Connect the signal power supply 5V positive and switch to the COM 24V interface above +5V.
MF-	Motor release signal	When it is effective (low level), turn off the motor wiring current, the driver stops working, and the motor is in free state.
COM24V	24 V common terminal	The pulse direction port defaults to a 5V signal input, but when zeroing in the internal position mode it is connected to a 24V sensor signal and needs to be switched to the COM24V interface. COM24V is the 24V common cathode and common anode input terminal. If you use the common anode connection method to input 24V pulse signal, you only need to connect 24V+ to COM24V and 24V- to PU-. Common cathode connection, 24V+ connects to PU+, 24V- connects to COM24V.
V-	Power supply -	DC20V~50V
V+	Power supply +	
A+	Motor connecting wire	
A-		
B+		
B-		
A	485 communication A phase signal	
B	485 communication B phase signal	
GND	Power Ground	



DRIVERS---BHD2806

The BHD2806 is a new type of stepper driver successfully researched and developed according to the market demand and development trend. It adopts a new 32-bit motor control special DSP chip, which makes the motor run more smoothly and is not easy to lose steps. The BHD2806 receives input signal pulse, direction and enable input. When using the internal position, the pulse and direction interfaces can be used for sensor signal input and accept 485 control operation. The motor's heat generation and vibration amplitude are reduced to a minimum, thus better improving machining speed and accuracy of machine operation. Operating voltage is AC18V-80V/DC25-110V, and is compatible with various types of two-phase stepper motors with currents up to 6.0A and outer diameters from 57 to 86mm.

Technical characteristics

- Brand new 32-bit DSP chip for motor control;
- Can drive stepper motors in the 86 series and below;
- Pulse response frequencies up to 200 Kpps;
- Opto-isolated signal input;
- High speed, high torque, high energy efficiency;
- With overcurrent, over-voltage protection.

Electrical Specification

Specifications	Minimum value	Typical value	Peak value	Unit
Continuous output current	0	6	8.4	A
Input power voltage	+18v	--	100v	Vac
Pulse frequency	0	--	200	KHZ
Input signal current	7	10	20	MA
insulation resistance	500	--	--	MΩ

Operating environment and parameters

Cooling method	Natural wind cooling or forced cooling		
Ambient environment	Environment	No corrosive gas or dust, etc. Cannot be used in special environments such as radioactive materials, magnetic fields, and vacuum.	
	Temperature	0--- +50°C	
	Humidity	Under 85%(no dew)	
Storage temperature	-20°C~80°C		
Weight	Around 600 grams		
Dimensions	150×53×97.5mm.3		

External terminal descriptio



Current setting

SW1	SW2	SW3	Bus. In (A)
ON	ON	ON	2.0
OFF	ON	ON	2.5
ON	OFF	ON	3.2
OFF	OFF	ON	3.8
ON	ON	OFF	4.2
OFF	ON	OFF	4.8
ON	OFF	OFF	5.3
OFF	OFF	OFF	6.0

SW4: OFF=Half Current ON=Full Current

Subdivision setting

SW5	SW6	SW7	SW8	Step (puls/r)	Speed (rpm)
ON	ON	ON	ON	10	400
OFF	ON	ON	ON	20	800
ON	OFF	ON	ON	30	1600
OFF	OFF	ON	ON	50	3200
ON	ON	OFF	ON	60	6400
OFF	ON	OFF	ON	80	12800
ON	OFF	OFF	ON	100	25600
OFF	OFF	OFF	ON	150	51200
ON	ON	ON	OFF	200	1000
OFF	ON	ON	OFF	250	2000
ON	OFF	ON	OFF	300	4000
OFF	OFF	ON	OFF	400	5000
ON	ON	OFF	OFF	500	8000
OFF	ON	OFF	OFF	600	10000
ON	OFF	OFF	OFF	700	20000
OFF	OFF	OFF	OFF	800	40000

SW9	ON	Double pulse mode: CW/CCW
OFF	1/1/0 mode: PU is pulse signal, DR is direction signal	
SW15	ON	Accept 1/0 input
OFF	Accept pulse input	

POW (G) ALM (R)

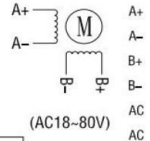
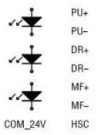

Dimensions

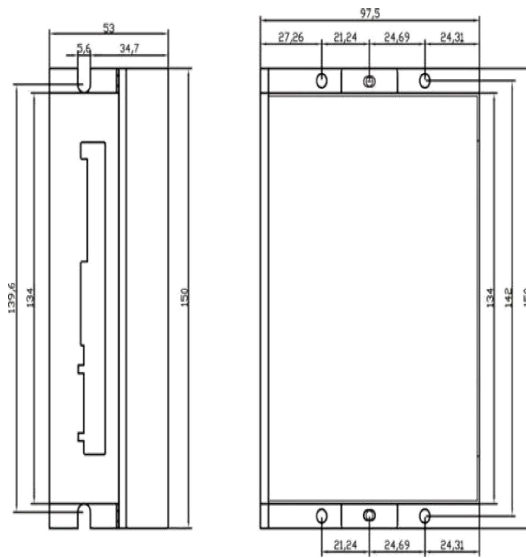

Subdivision settings / I / O mode settings

The subdivision (micro step) setting and the I/O mode setting are controlled by the dip switch SW10. When SW10=OFF, it is subdivision setting mode; when SW10=ON, it is I/O mode. The subdivision and speed are set by the DIP switch SW5-SW8, total 16 steps.

subdivision number (puls/r)	400	800	1600	3200	6400	12800	25600	51200
Speed (rpm)	10	20	30	50	60	80	100	150
SW5	ON	OFF	ON	OFF	ON	OFF	ON	OFF
SW6	ON	ON	OFF	OFF	ON	ON	OFF	OFF
SW7	ON	ON	ON	ON	OFF	OFF	OFF	OFF
SW8	ON	ON	ON	ON	ON	ON	ON	ON
subdivision number (puls/r)	1000	2000	4000	5000	8000	10000	20000	40000
Speed (rpm)	200	250	300	400	500	600	700	800
SW5	ON	OFF	ON	OFF	ON	OFF	ON	OFF
SW6	ON	ON	OFF	OFF	ON	ON	OFF	OFF
SW7	ON	ON	ON	ON	OFF	OFF	OFF	OFF
SW8	OFF	OFF	OFF	OFF	OFF	OFF	OFF	OFF
SW9	ON: dual pulse. PU is a forward stepping pulse signal and DR is a reverse stepping pulse signal. OFF: single pulse. PU is the stepping pulse signal and DR is the directional control signal.							
SW10	ON: I/O mode, speed mode. OFF: position mode, accepting external pulse.							

The operating current of the driver is set by the DIP switches SW1-SW3, and the operating current is the effective output current. Peak current = operating current × 1.4.

Operating current (A)	2.0	2.5	3.2	3.8	4.2	4.8	5.3	6.0
Peak current (A)	2.8	3.5	4.5	5.3	5.9	6.7	7.4	8.4
SW1	ON	OFF	ON	OFF	ON	OFF	ON	OFF
SW2	ON	ON	OFF	OFF	ON	ON	OFF	OFF
SW3	ON	ON	ON	ON	OFF	OFF	OFF	OFF

When SW4 is turned off, the current will be automatically halved when it is stopped by default. When turned on, the drive will always output full current according to the set current.

Pin function description

Symbol	Name	Note
PU+	Pulse signal +	Connect to signal power positive terminal, amplitude range +5V.
PU-	Pulse signal -	The falling edge is valid, the motor takes one step when the pulse changes from high to low, the input resistance is 220Ω, the requirements are: low level 0-0.5V, high level more than 4V, pulse width >2.5μs.
DR+	Direction signal +	Connect to signal power positive terminal, amplitude range +5V.
DR-	Direction signal -	Used to change the direction of the motor. Input resistance 220 Ω, requirements: low level 0-0.5v, high level greater than 4V, pulse width > 2.5 μ s.
MF+	Enable signal +	Connect to signal power positive terminal, amplitude range +5V.
MF-	Enable signal -	When it is effective (low level), turn off the motor wiring current, the driver stops working, and the motor is in free state.
COM24V HSC	24 V common terminal	COM24V is the 24V common cathode and common anode input terminal. If you use the common anode connection method to input 24V pulse signal, you only need to connect 24V+ to COM24V and 24V- to PU-. Common cathode connection, 24V+ connects to PU+, 24V- connects to COM24V.
V-	Power supply -	AC18V-80V/DC25-110V
V+	Power supply +	
A+	Motor connecting wire	
A-		
B+		
B-		
A	485 communication A phase signal	
V-	Power supply -	
V+	Power supply +	



Schematic diagram of driver wiring & size

DRIVERS---BHD2178

BHD2178 product series is a new generation of two-phase high voltage hybrid stepping motor digital driver based on DSP controlled, suitable for various types of two-phase hybrid stepping motor with current 8.0A below and outside diameter 57-130mm. The internal circuit of the driver is similar to the servo control principle, which can make the motor run smoothly without vibration and noise. The torque of the motor at high speed is far greater than that of similar products in the market, and the positioning accuracy can reach up to 40000 step / turn. The products are widely used in woodworking engraving machine, medium-sized CNC machine tools, computer embroidery machine, packaging machinery.

Technical characteristics

- Setting 16 gears angle constant torque subdivision, and the highest resolution is 40000 step / turn
- The highest response frequency can be up to 500Kpps
- If step pulse stops more than 1.5s, coil current will reduce to half of the setting current automatically.
- Photoelectric isolation signal input / output
- Current effective value of driver is from 0.5A/ phase to 8.0A/ phase which can be divided into 16 grades adjustable.
- with single power supply input, voltage range: AC40V-110V
- Phase memory function (Note: after the input stops for more than 3 seconds, the driver will automatically remember the motor phase at that time.
- When the power is turned on again or the MF signal changes from low level to high level, the driver will automatically restore the motor phase).

Current setting

The working current of the driver is set by D1-D4 terminals, and the operating current is the normal working output current setting switch (see the table below for details)

Running current (A)	0.5	1.0	1.5	2.0	2.5	3.0	3.5	4.0	4.5	5.0	5.5	6.0	6.5	7.0	7.5	8.0
D1	OFF	OFF	OFF	OFF	OFF	OFF	OFF	OFF	ON	ON	ON	ON	ON	ON	ON	ON
D2	OFF	OFF	OFF	OFF	ON	ON	ON	ON	OFF	OFF	OFF	OFF	ON	ON	ON	ON
D3	OFF	OFF	ON	ON	OFF	OFF	ON	ON	OFF	OFF	ON	ON	OFF	OFF	ON	ON
D4	OFF	ON	OFF	ON	OFF	ON	OFF	ON	OFF	ON	OFF	ON	OFF	ON	OFF	ON

Pin function description

Port definition	No. of connector pin	Marking symbol	Function	Note
DB15	1	5PU+	Positive input end of photoelectric isolated I/O	Connected to +5V power supply, +5V - +24V can be driven, higher than +5V need to connect current limiting resistor
	2	PU-	DP9= OFF, PU is stepping pulse signal	The falling edge is valid. When the pulse changes from high to low, the motor moves one step, and the input resistance is 220Ω. Requirements: low level 0-0.5v, high level 4-5v, pulse width > 2.5 μs
			DP9=ON, PU is positive phase of stepping pulse signal	
	3	5DR+	Positive input end of photoelectric isolated I/O	Connected to +5V power supply, +5V - +24V can be driven, higher than +5V need to connect current limiting resistor
	4	DR-	DP9= OFF, DR is direction control signal	Used to change the direction of the motor. Input resistance 220Ω, requirements: low level 0-0.5v, high level 4-5v, pulse width > 2.5 μs
			DP9=ON, DR is negative direction of stepping pulse signal	
	7	5MF+	Positive input end of photoelectric isolated I/O	Connected to +5V power supply, +5V - +24V can be driven, higher than +5V need to connect current limiting resistor
	8	MF-	Motor release signal	When effective (low level), turn off the motor coil current, the driver stops working, and the motor is in the release state.
	9	ALM+	Positive fault output signal end of Photoelectric isolated I/O	When the driver has over-current or overheat fault, the driver outputs fault signal, which is valid (low level)
	10	ALM-	Negative fault output signal end of Photoelectric isolated I/O	
	11	RDY+	The driver is ready to output the signal to the positive end of photoelectric isolated I/O	The driver status is normal, and the signal is valid when it is ready to receive the driver signal (low level)
	12	RDY-	The driver is ready to output the signal to the negative end of photoelectric isolated I/O	
	13	24PU+	Positive input end of photoelectric isolated I/O	+24 V driveable
	14	24DR+	Positive input end of photoelectric isolated I/O	+24 V driveable
	15	24MF+	Positive input end of photoelectric isolated I/O	+24 V driveable
Motor and power terminal	1、2	L1、L2	Power supply	Power: AC40-110V
	3	A+	Motor wiring	

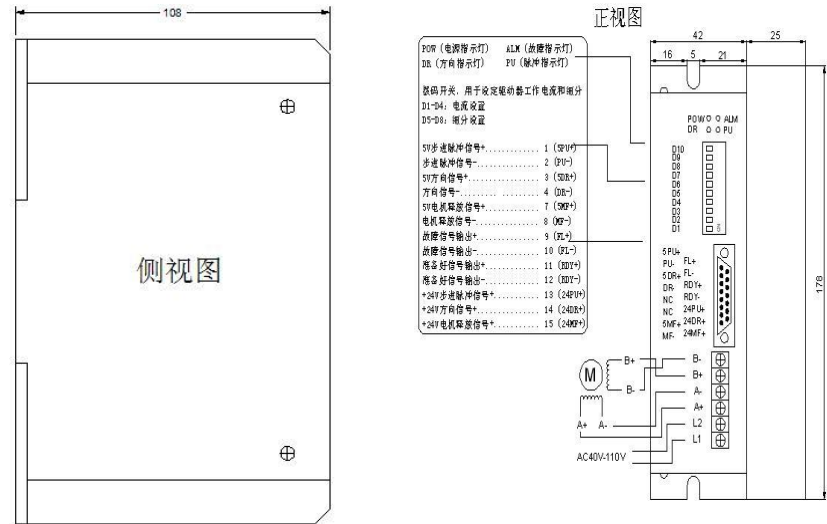

Pin function description

Port definition	Marking symbol	Function	Note
DB15	5PU+	Positive input end of photoelectric isolated I/O	Connected to +5V power supply, +5V - +24V can be driven, higher than +5V need to connect current limiting resistor
	PU-	DP9= OFF, PU is stepping pulse signal	The falling edge is valid. When the pulse changes from high to low, the motor moves one step, and the input resistance is 220Ω. Requirements: low level 0-0.5v, high level 4-5v, pulse width > 2.5 μs
		DP9=ON, PU is positive phase of stepping pulse signal	
	5DR+	Positive input end of photoelectric isolated I/O	Connected to +5V power supply, +5V - +24V can be driven, higher than +5V need to connect current limiting resistor
	DR-	DP9= OFF, DR is direction control signal	Used to change the direction of the motor. Input resistance 220Ω, requirements: low level 0-0.5v, high level 4-5v, pulse width > 2.5 μs
		DP9=ON, DR is negative direction of stepping pulse signal	
	5MF+	Positive input end of photoelectric isolated I/O	Connected to +5V power supply, +5V - +24V can be driven, higher than +5V need to connect current limiting resistor
	MF-	Motor release signal	When effective (low level), turn off the motor coil current, the driver stops working, and the motor is in the release state.
	ALM+	Positive fault output signal end of Photoelectric isolated I/O	When the driver has over-current or overheat fault, the driver outputs fault signal, which is valid (low level)
	ALM-	Negative fault output signal end of Photoelectric isolated I/O	
	RDY+	The driver is ready to output the signal to the positive end of photoelectric isolated I/O	The driver status is normal, and the signal is valid when it is ready to receive the driver signal (low level)
	RDY-	The driver is ready to output the signal to the negative end of photoelectric isolated I/O	
	24PU+	Positive input end of photoelectric isolated I/O	+24 V driveable
	24DR+	Positive input end of photoelectric isolated I/O	+24 V driveable
	24MF+	Positive input end of photoelectric isolated I/O	+24 V driveable
Motor and power terminal	L1、L2	Power supply	Power: AC40-110V
	A+	Motor wiring	



DRIVERS---BHD3278

BHD3278 product series is a new generation of three-phase high voltage stepping motor drive, which is designed basing on high-speed DSP + IPM DIGITAL three-phase stepper motor driver and added advanced intelligent control algorithms. Compared with ordinary DSP + IPM model, the new type has improved greatly in many aspects that includes motor adaptation, external signal adaptation, receiving pulse frequency, service life, reliability, stability, and almost without vibration or noise. This new driver is suitable for various types of three-phase hybrid stepping motor with current 7.0A below and outside diameter 57-130mm(torque range: 2NM-60NM). Position accuracy can reach the highest 6000 step/turn. This serious of products have the biggest feature of some types integrating motion control function in internal, supporting touch screen control and data input, and according to customer needs ,pre-installing punch cutting system, automatic feeding and cutting system or customized arbitrarily complex single axis motion control function.

This driver internal integrate digital IO interface of 4 into and 2 out, can meet general motion control requirements. The products are widely used in large and medium-size high resolution digital control equipments of engraving machine, crystal grinding machine, medium-size digital control machine tool, computer embroidery machine, packaging machinery, cutting and feeding system, etc.

Features

- High and low voltage dual mode is suitable for 50V low voltage to 300V high voltage motor.
- Single and double pulse dual mode is suitable for pulse + direction mode and CW, CCW double pulse mode.
- With large torque, communication control mode etc, it is suitable for application
- Integrating motion control function, omitting PLC or motion controller
- It can be controlled by touch screen directly or download parameter.
- Setting 16 gears angle constant torque subdivision, and the highest resolution is 60000 step / turn
- The highest response frequency can be up to 500Kpps, and it is 2.5 times as fast as traditional driver.
- If step pulse stops more than 100ms, coil current will reduce to half of the setting current automatically.
- Photoelectric isolation signal input / output
- 5V, 12V, 24V signal input is compatible, and it's no need to set current limit resistor external.
- Current effective value of driver is from 1.2AV phase to 7.0AV phase which can be divided into 16 grades adjustable.
- with single power supply input, voltage range: AC80V-240V

Current Setting

Drive working current is set by DIP-1 end, and running current is normal working output current.

Running current (A)	1.2	1.5	2.0	2.3	2.5	3.0	3.2	3.6	4.0	4.5	5.0	5.3	5.8	6.2	6.5	7.0
D1	OFF	OFF	OFF	OFF	OFF	OFF	OFF	OFF	ON	ON	ON	ON	ON	ON	ON	ON
D2	OFF	OFF	OFF	OFF	ON	ON	ON	ON	OFF	OFF	OFF	OFF	ON	ON	ON	ON
D3	OFF	OFF	ON	ON	OFF	OFF	ON	ON	OFF	OFF	ON	ON	OFF	OFF	ON	ON
D4	OFF	ON	OFF	ON	OFF	ON	OFF	ON	OFF	ON	OFF	ON	OFF	ON	OFF	ON

Subdivision setting

Driver subdivision is set by DIP-2 end, and has 16 archives in total. It is set respectively by the first four ones of six dial switches, and the last two

are for function setting. Form below is fine fraction (pulse per revolution) for reference.

Fine Fraction	400	500	600	800	1000	1200	2000	3000	4000	5000	6000	10000	12000	20000	30000	60000
D1	ON	ON	ON	ON	ON	ON	ON	ON	OFF	OFF	OFF	OFF	OFF	OFF	OFF	OFF
D2	ON	ON	ON	ON	OFF	OFF	OFF	OFF	ON	ON	ON	ON	OFF	OFF	OFF	OFF
D3	ON	ON	OFF	OFF	ON	ON	OFF	OFF	ON	ON	OFF	OFF	ON	ON	OFF	OFF
D4	ON	OFF	ON	OFF	ON	OFF	ON	OFF	ON	OFF	ON	OFF	ON	OFF	ON	OFF
D5	ON, M type is for the double pulse control model, MA type is for large torque model, MB type is for the serial model, MC type is for the control function, MD is for low voltage motor adaptation mode.															
D6	OFF, M type is for single pulse control mode, MA, MB, MC, MD types are for the normal mode.															
D6	Automatic detection switch (OFF: receives external pulse, ON: inside of drive runs 30 turns per minute speed.															

Control signal input

All input signals are through the photoelectric isolation, and signal interface has not only 5v interface but also 12v / 24v interface. Users don't

need external current limiting resistor. It supports differential mode input and anode sharing or cathode sharing input.



Pin function description

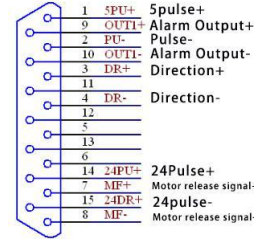

end definition	stitch No	Mark symbol	function	remark	
RS-232	1	RX	Receive data	Connect to a serial RX (part model support)	
	2	TX	Send data	Connect to a serial TX (part model support)	
	8	GND	Earth line	Connect to a serial(part model support)	
DB15	1	5PU+	5V pulse signal photoelectric isolation input plus end	If external signal is 5V, please connect to 5PU+, 5DR+, MF+ and PU-, DR-, MF-; If external signal is 12V or 24V, please connect to 24PU+, 24DR+, MF+ and PU-, DR-, MF-;	
	2	PU-	pulse signal photoelectric isolation input negative terminal		
	3	5DR+	5V direction signal photoelectric isolation input plus end		
	4	DR-	direction signal photoelectric isolation input plus end		
	7	MF+	Motor releasing signal photoelectric isolation plus end		
	8	MF-	Motor releases signal, and if effective, motor in a free state		
	14	24PU+	12V/24V pulse signal photoelectric isolation input plus end		
	15	24DR+	12V/24V direction signal photoelectric isolation input plus end		
	9	OUT1+	Fault signal output plus end		The signal is also called ALM signal. If there s no failure, resistance between OUT1 + and OUT1 - is more than 1M ohm. And if there is drive failure, resistance between pins less than 10 ohm. Must pay attention to limit current, and drive internal can bear 100 mA current.
	10	OUT2-	Fault signal output negative terminal		
motor and power end	5, 6, 11, 12, 13,	NC	Function preservation	Please keep impending state	
	1, 2	L, N	Power supply	recommendation: AC110~250V The biggest moment can bear 380 v	
	3	PE	Earth line	earth (inside connect to driver shell)	
	4	U	motor connection line		